

Las piezas se unen entre si con clavos espiralados de  $\varnothing 3,4$  mm

| LISTA DE PARTES |       |          |             |          |
|-----------------|-------|----------|-------------|----------|
| ITEM            | CTDAD | NOMBRE   | MEDIDAS     | MATERIAL |
| 1               | 7     | TABLA #1 | 120x20x1422 | TARARA   |
| 2               | 3     | TABLA #2 | 120x20x1118 | TARARA   |
| 3               | 9     | TACOS    | 120x120x60  | PINO     |
| 4               | 2     | TABLA #3 | 95x20x1118  | TARARA   |
| 5               | 3     | TABLA #4 | 120x20x1232 | TARARA   |
| PESO DEL PALLET |       |          |             |          |
| 43 Kg (Aprox.)  |       |          |             |          |





CÓDIGO  
PLN-S-PCBN

## PLANO REFERENCIAL

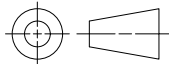
|            |  |          |  |  |   |   |
|------------|--|----------|--|--|---|---|
| DIBUJADO   |  | FIRMA    |  | NOMBRE DE PLANO:<br>PALLET RETORNABLE<br>1118 x 1422 | FORMATO<br><b>A4</b>  | ESCALA<br><b>1:20</b>   |
| REVISADO   |  | APROBADO |  | PROYECTO:<br>PALLETS ENVIBOL                         |  | DIMENSIONES:<br>mm  |
| SOLICITADO |  |          |  | Fecha de aprobación:<br>17.2.2021                    |   |  |

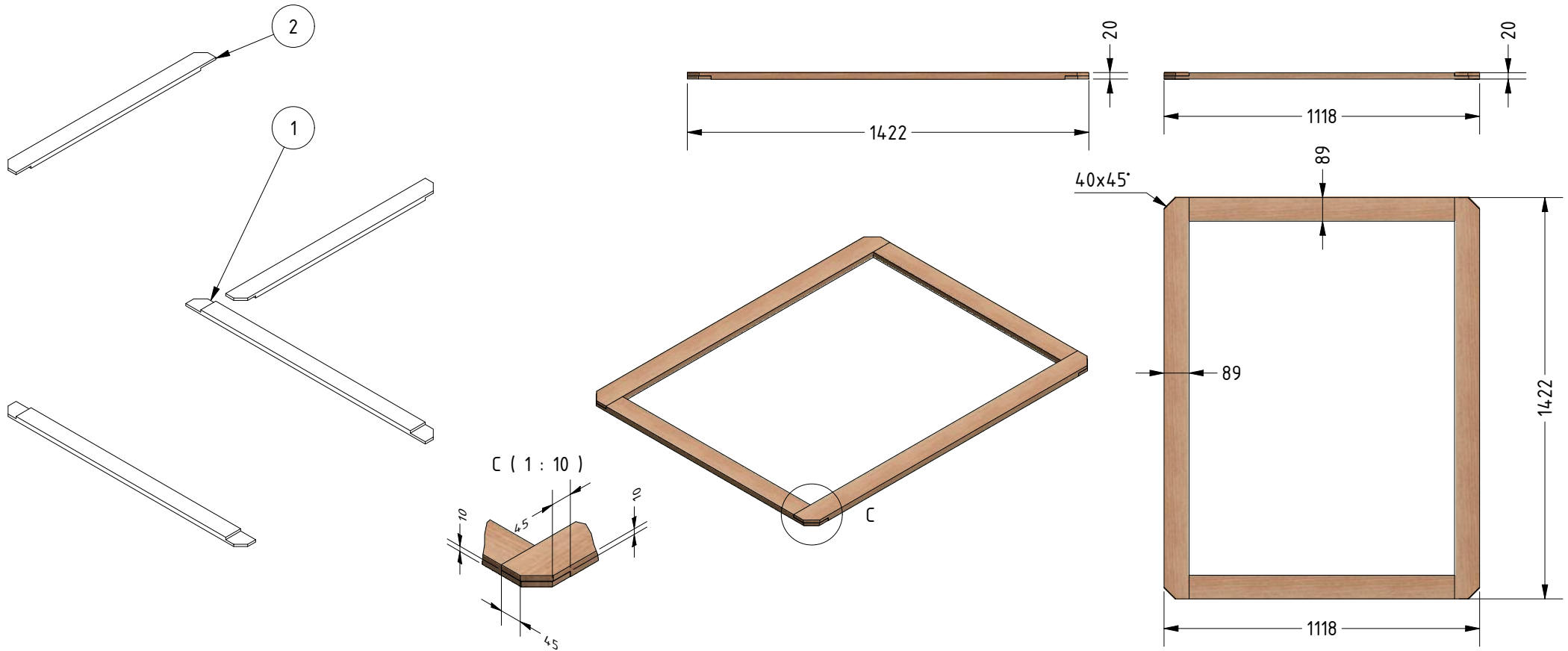

| PARTS LIST |     |                      |             |          |
|------------|-----|----------------------|-------------|----------|
| ITEM       | QTY | PART NUMBER          | DESCRIPTION | MATERIAL |
| 1          | 2   | TABLA DE MARCO 1 CBN | 89x20x1118  | TARARA   |
| 2          | 2   | TABLA DE MARCO 2 CBN | 89x20x1422  | TARARA   |



CÓDIGO  
PLN-S-PLLT

## PLANO REFERENCIAL

|         |        |
|---------|--------|
| Versión | 1      |
| Página  | 2 de 2 |

|            | NOMBRE | FIRMA | NOMBRE DE PLANO:                   | FORMATO | ESCALA             |
|------------|--------|-------|------------------------------------|---------|--------------------|
| DIBUJADO   |        |       | MARCO SUPERIOR<br>RETORNABLE       | A4      | 1:20               |
| REVISADO   |        |       | PROYECTO:<br>PALLET DE USO GENERAL |         | DIMENSIONES:<br>mm |
| APROBADO   |        |       | Fecha de aprobación:<br>5.1.2021   |         |                    |
| SOLICITADO |        |       |                                    |         |                    |